

1

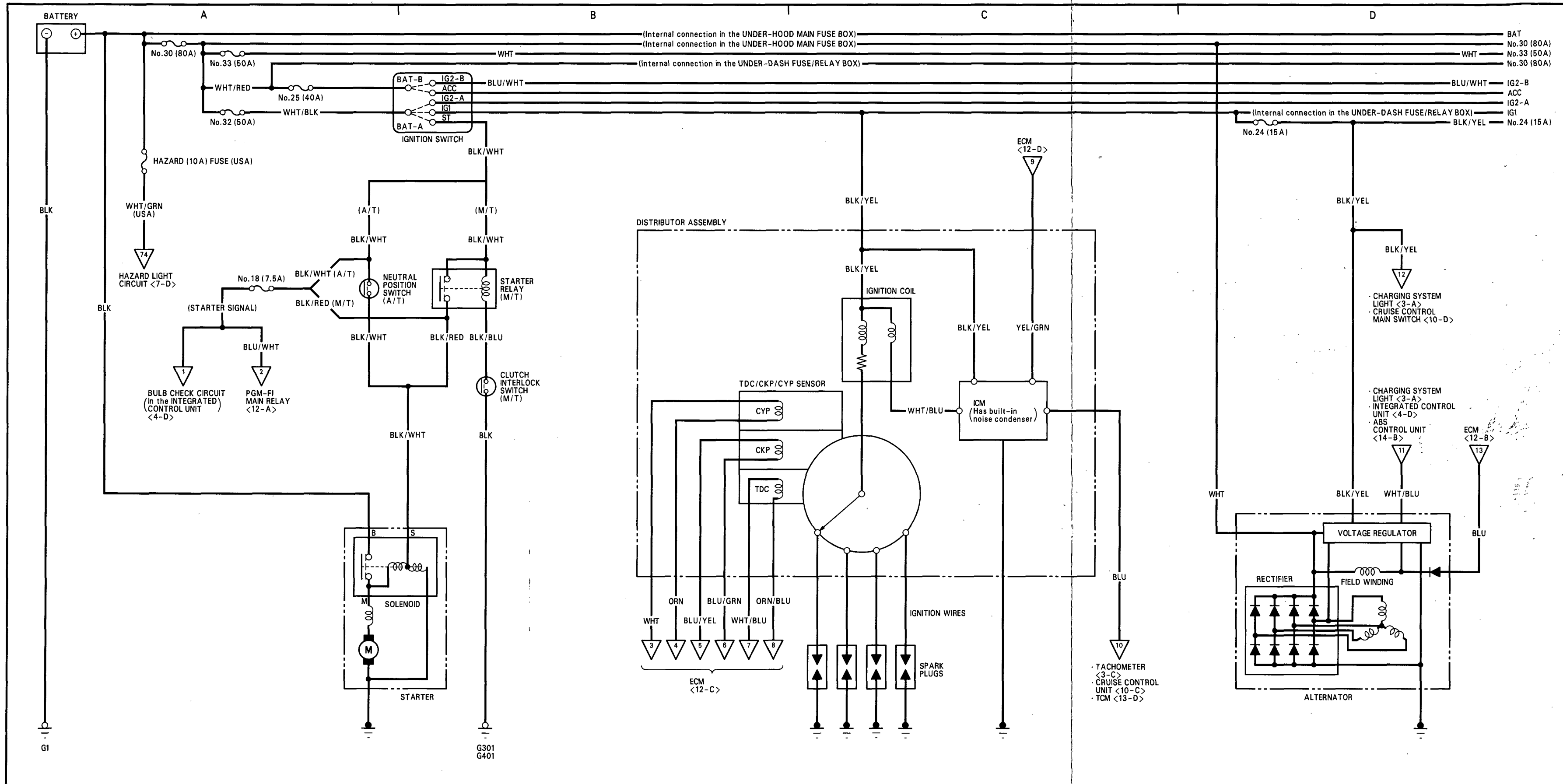

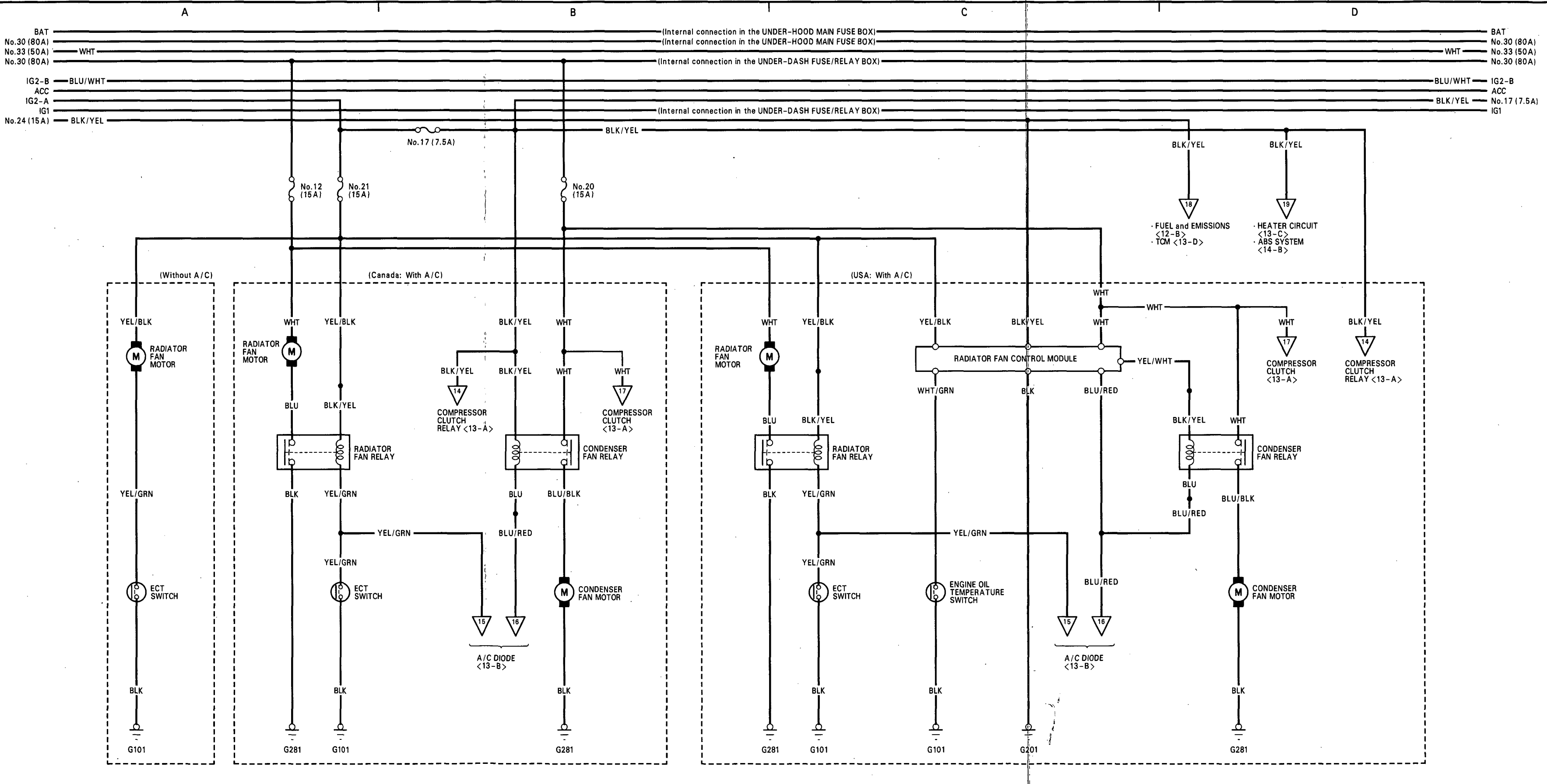

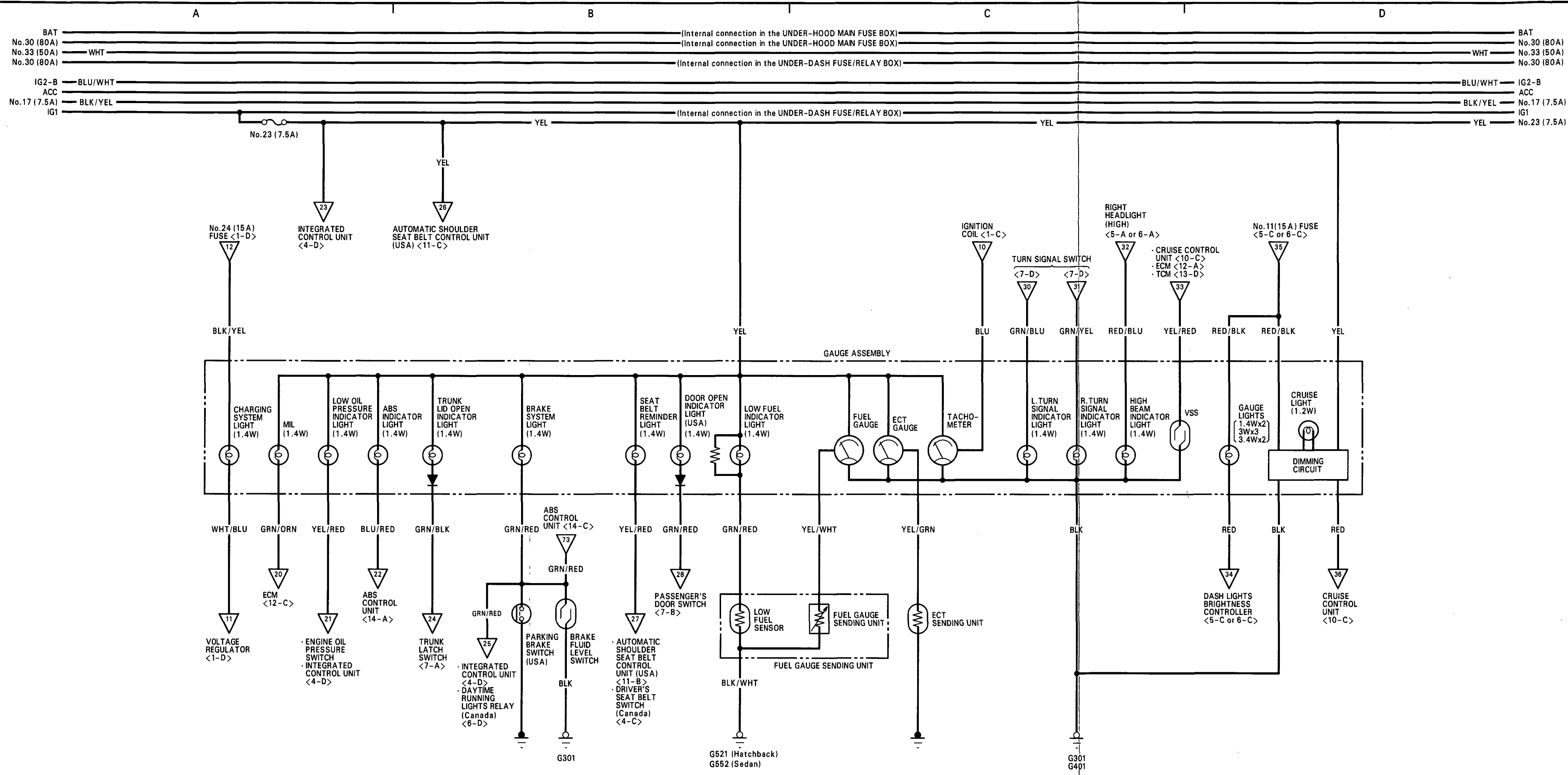

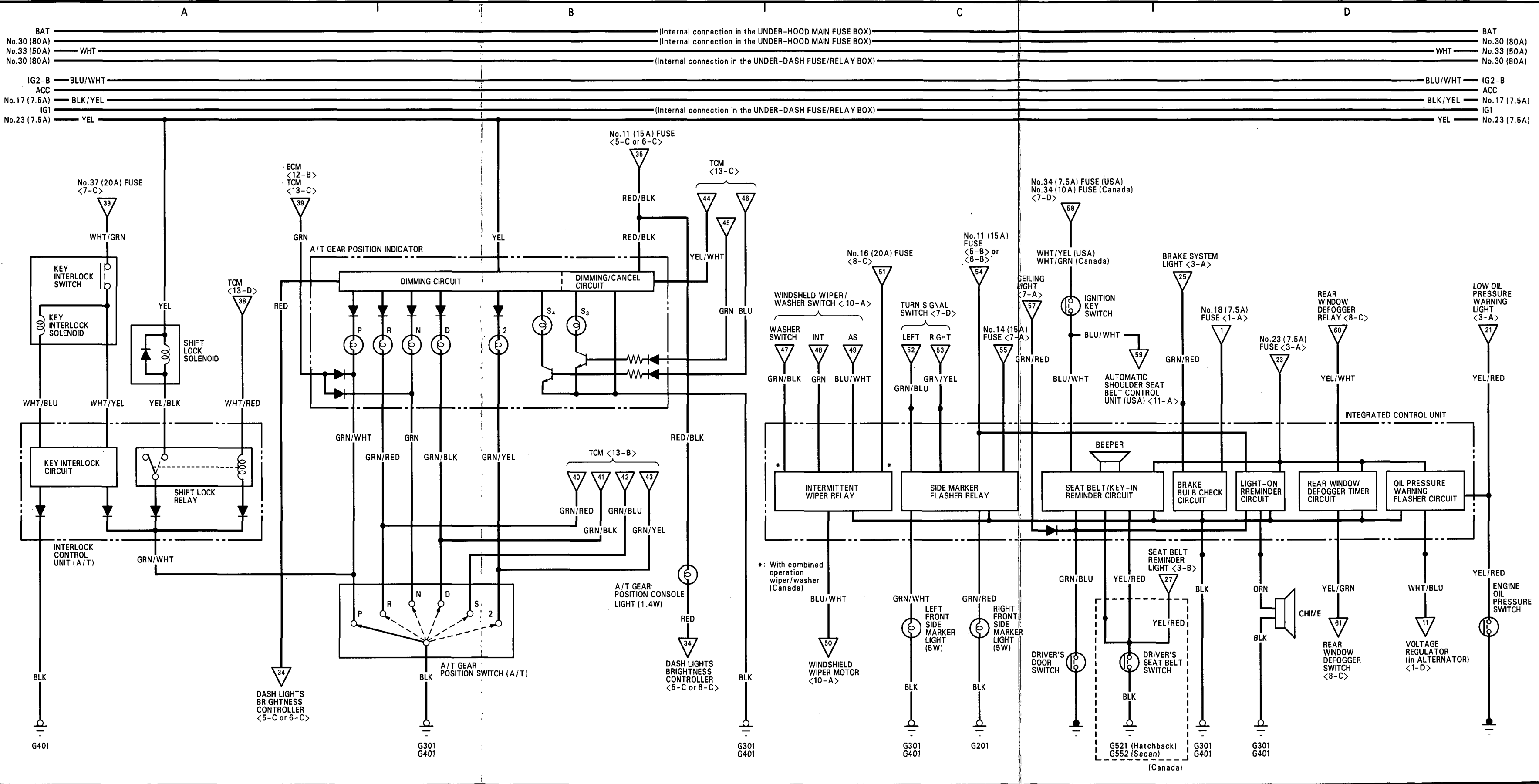

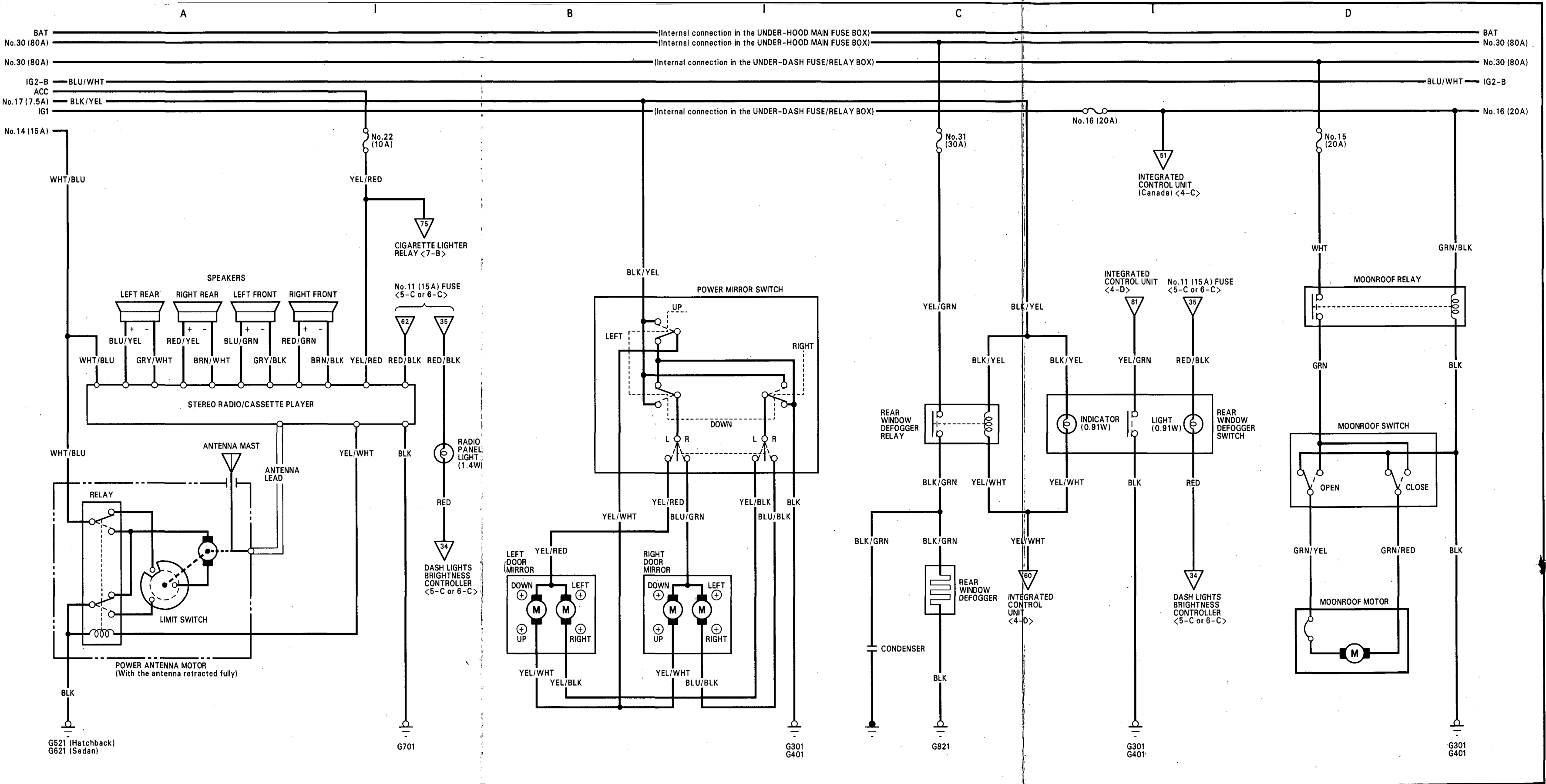

G521 (Hatchback)
G621 (Sedan)

G701

G301
G401

G821

G301
G401

G301
G401

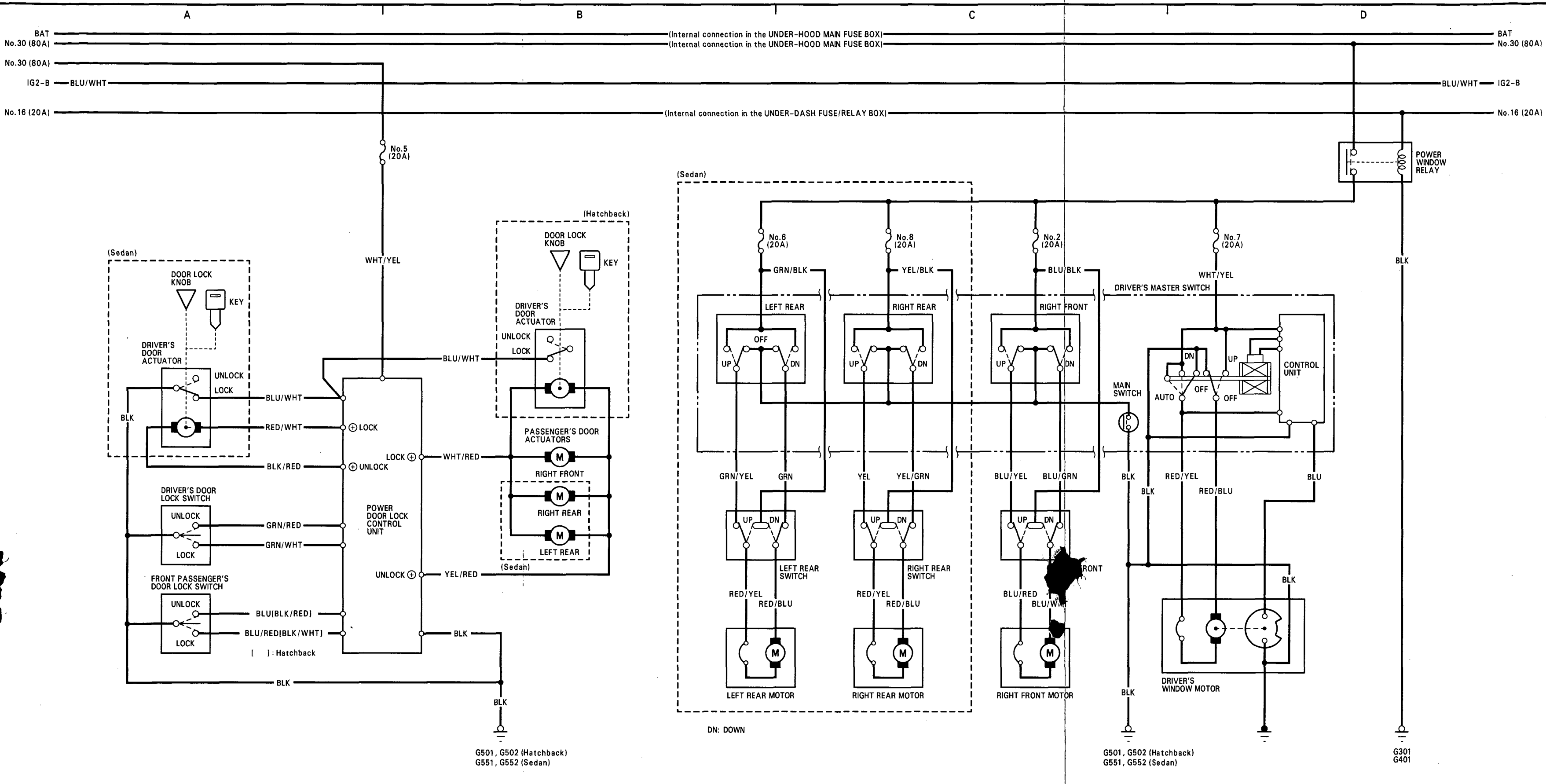

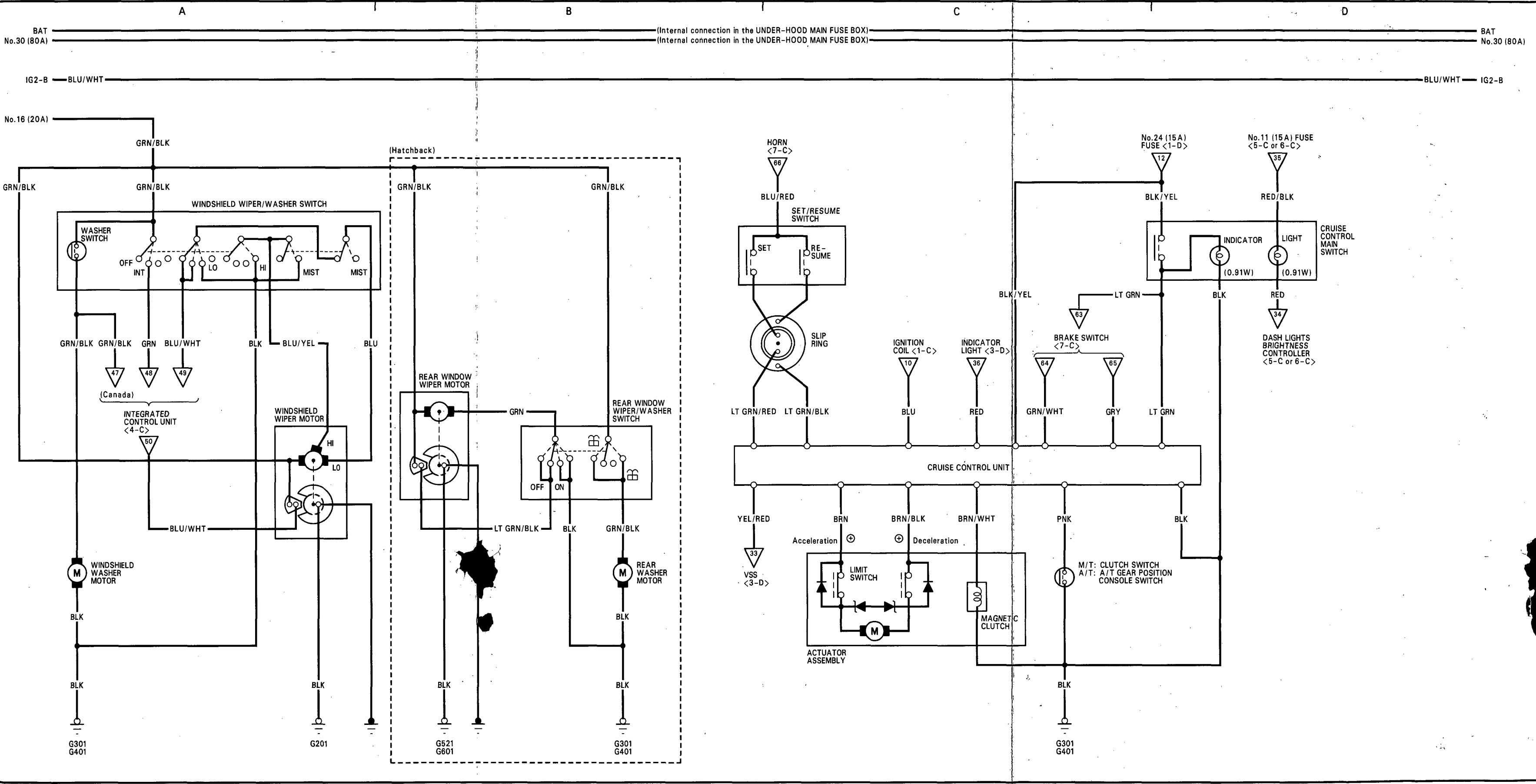

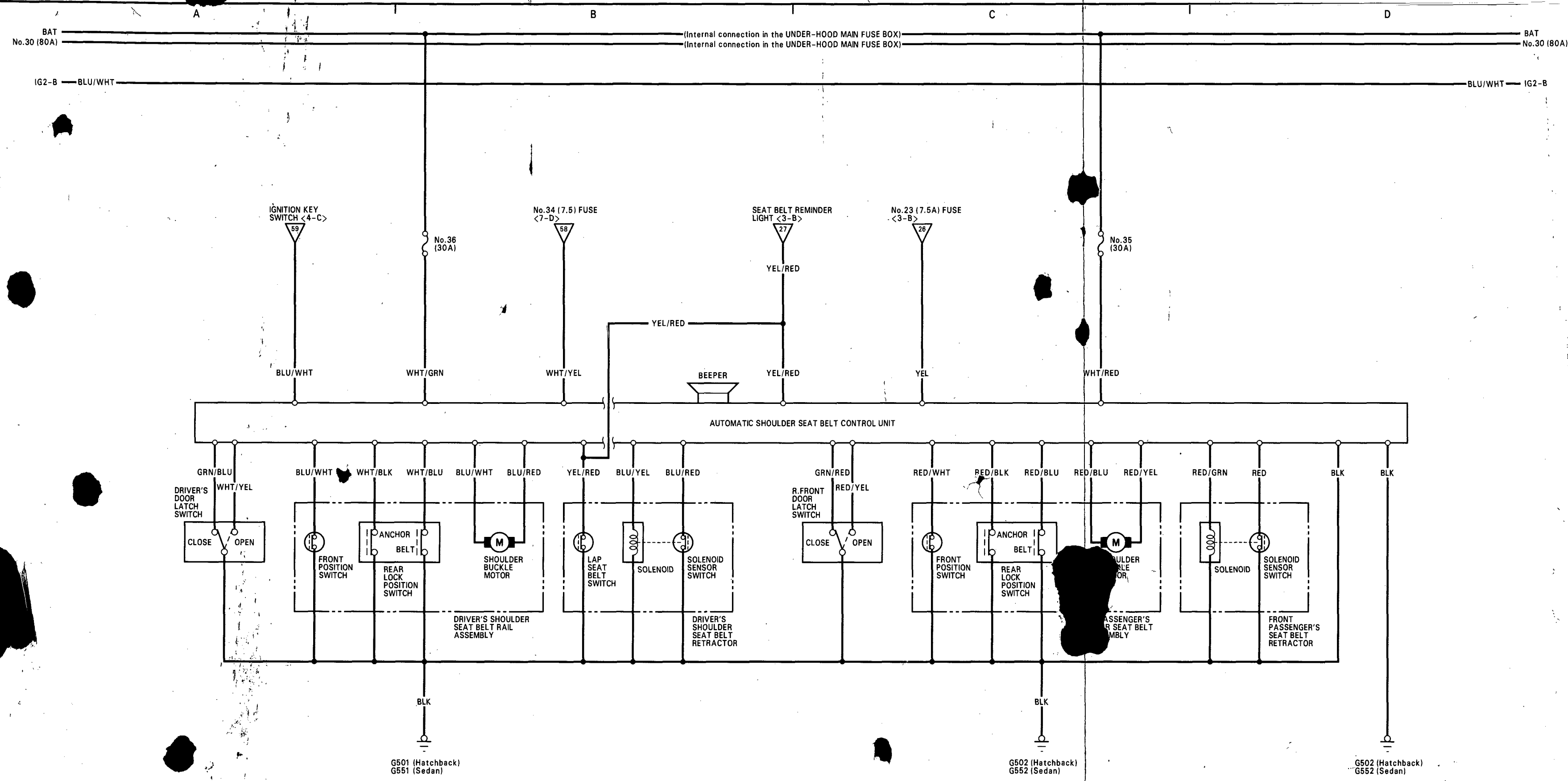

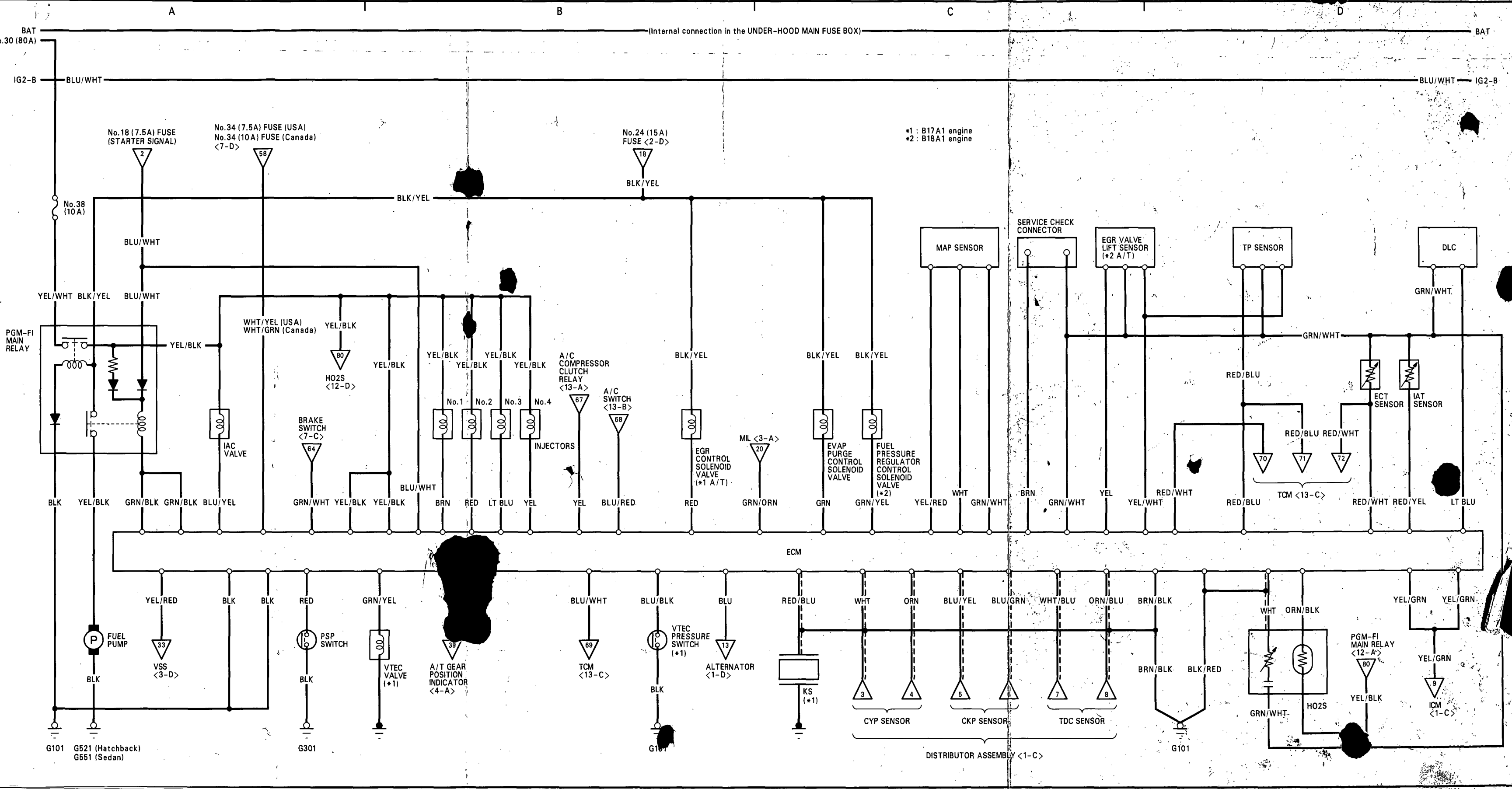

(Internal connection in the UNDER-HOOD MAIN FUSE BOX)

*1 : B17A1 engine
*2 : B18A1 engine

G101 G521 (Hatchback)
G551 (Sedan)

G301

G101

G101

DISTRIBUTOR ASSEMBLY <1-C>